

MOBILE
AND
FLEXIBLE
WEIGHING



SPECIAL WEIGHING SYSTEMS SERIES LW 1000

FACTS

- » Mobile design enables use at several locations
- » No platform required
- » Flexible synchronization options with all common packaging machines
- » Maximum accuracy
- » Product-specific equipment
- » Fully automatic calibration and taring
- » Dust and water-repellent design

TECHNICAL DATA

Dimensions (L x W x H):	In lowest lift position: 1879 x 1616 x 2098 (mm) In highest lift position: 1879 x 1616 x 2902 (mm)
Weight:	1.010kg
Attainable output:	Up to 150 weighings per minute
Volume weighing hoppers (absolute / usable):	400ccm / 150ccm
Automatic calibration:	Included as standard
Automatic taring:	Included as standard

Subject to change..

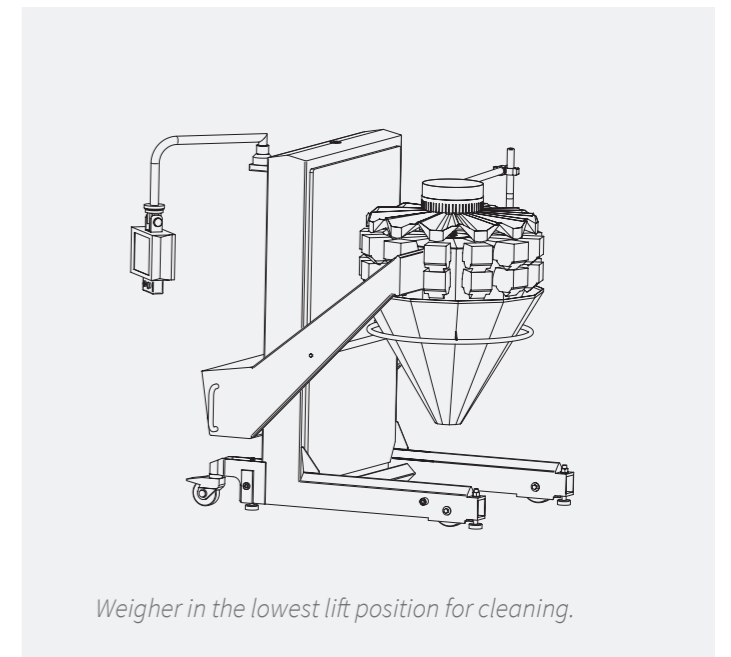
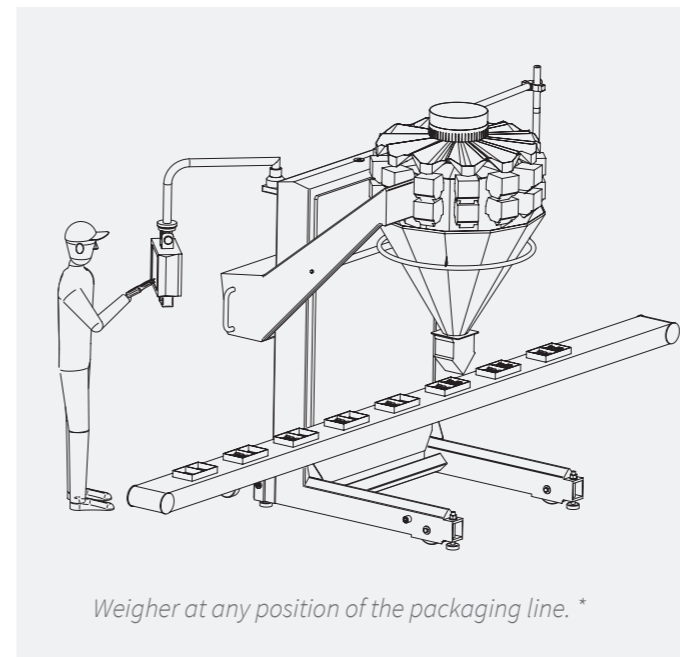

* Further combinations are possible.